

ABMESSUNGEN

CF sm 2 ROLLEN OBEN
AUFHÄNGUNG 2:1

| TYP | RH | RB | RT | C/2 | D | E | G | H |
|-----------|---------------|------------|-----|-----|-----|------------------------|-----|-----|
| CF sm630 | 2.150 - 2.750 | max. 1.200 | 800 | 50 | 225 | 330 (Rolle ≤ 400mm) | 350 | 300 |
| CF sm1000 | 2.150 - 2.750 | max. 1.500 | | | | | | |
| CF sm1600 | 2.150 - 2.750 | max. 1.600 | | | | | | |



CF sm 2 Rollen oben mit BF, Rollenführung

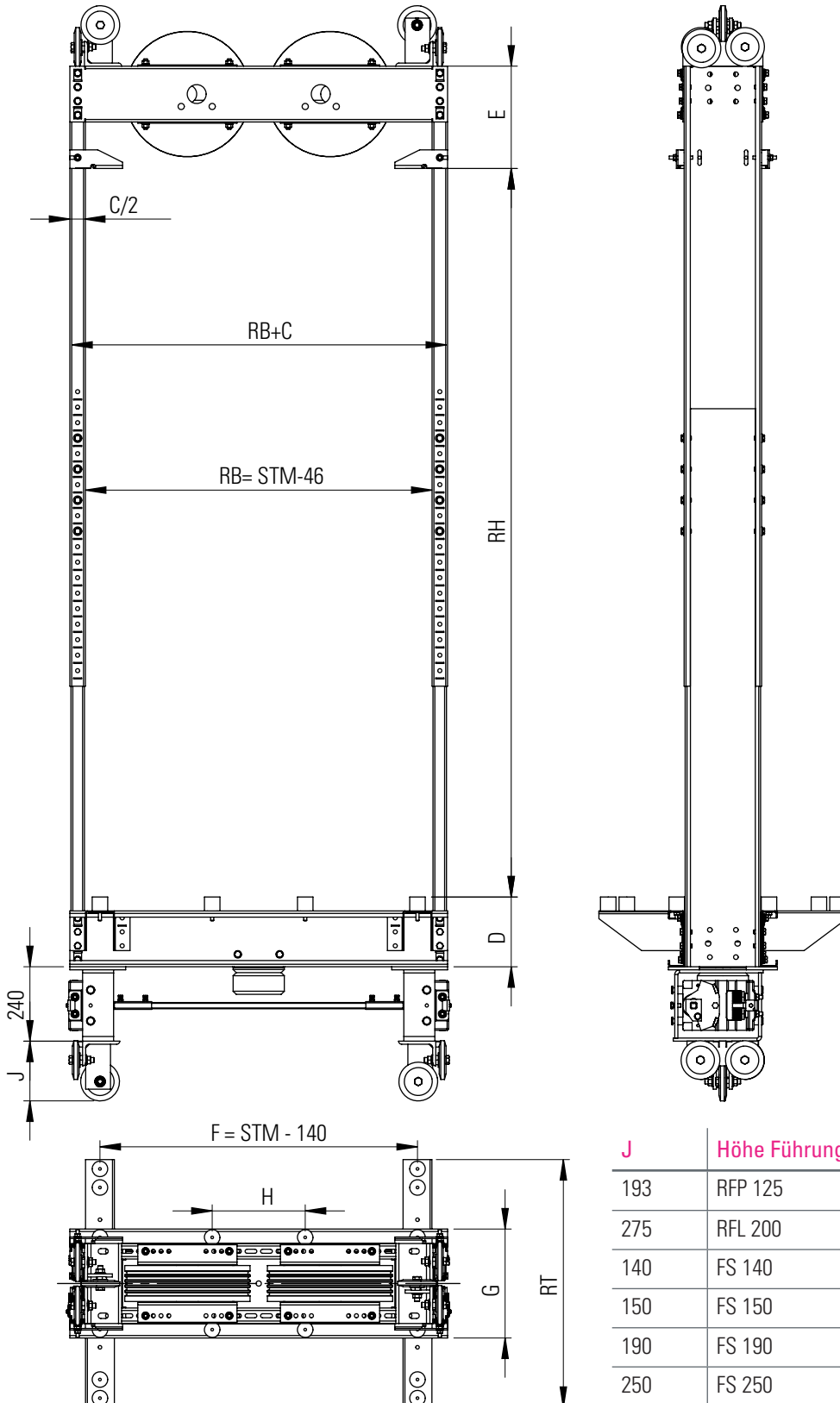

| | |
|------|----------------------------|
| STM | Führungsschienen-Stichmass |
| RH | Gesamthöhe Fahrkorb |
| RB | Fahrkorb aussen |
| RB+C | Rahmen aussen |
| RT | Rahmentiefe |

| J | Höhe Führungsrolle/-schuh |
|-----|---------------------------|
| 193 | RFP 125 |
| 275 | RFL 200 |
| 140 | FS 140 |
| 150 | FS 150 |
| 190 | FS 190 |
| 250 | FS 250 |