

ABMESSUNGEN

CF sm
AUFHÄNGUNG 1:1

TYP	RH	RB	RT	C/2	D	E	G	H
CF sm630	2.150.-2.750	max. 1.200	800	50	225	FV unten: 330 FV integriert: 390	350	300
CF sm1000	2.150 - 2.750	max. 1.500						
CF sm1600	2.150 - 2.750	max. 1.600						

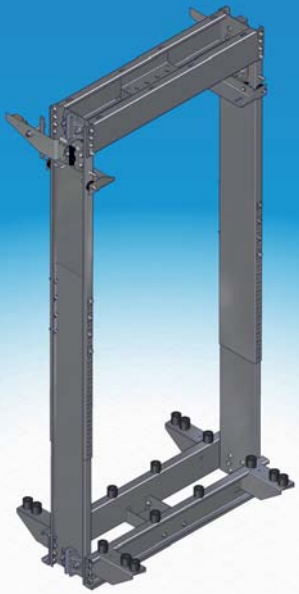

CF sm mit SG
Gleitführung

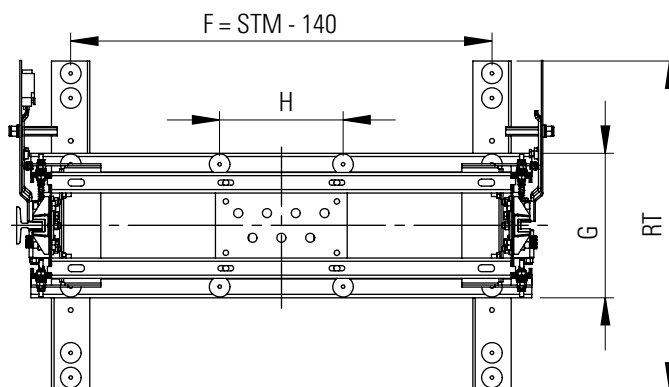
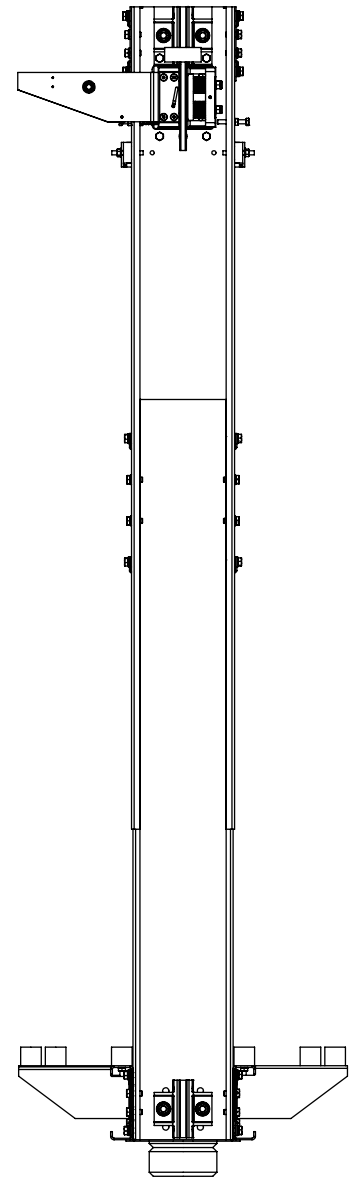
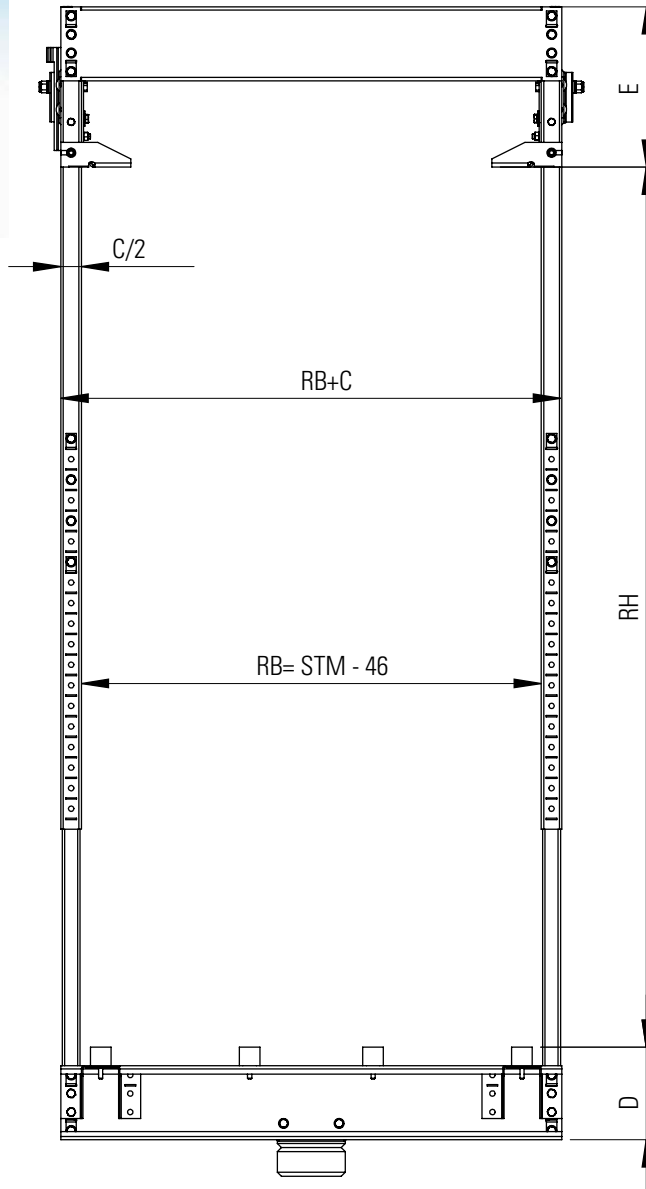

STM	Führungsschienen- Stichmass
RH	Gesamthöhe Fahrkorb
RB	Fahrkorb aussen
RB+C	Rahmen aussen
RT	Rahmentiefe