

ABMESSUNGEN

CF hrp  
AUFHÄNGUNG 2:1

TYP	RH	RB	RT	C/2	E	L	M	W
CF hrp2500	max. 3.200	max. 2.600	max. 4.000	60	Lasten- aufzug: 300	max. 140	180	max. 140
CF hrp4000	max. 5.000	max. 3.000	max. 5.000	80		max. 160	260	max. 200
CF hrp6300	max. 4.000	max. 3.060	max. 6.000	80	Personen- aufzug: 500	max. 200	300	max. 200
CF hrp10000	max. 4.500	max. 3.260	max. 7.000	100		max. 220	300	max. 200



CF hrp Rollen oben,  
mit BF, Gleitführungen

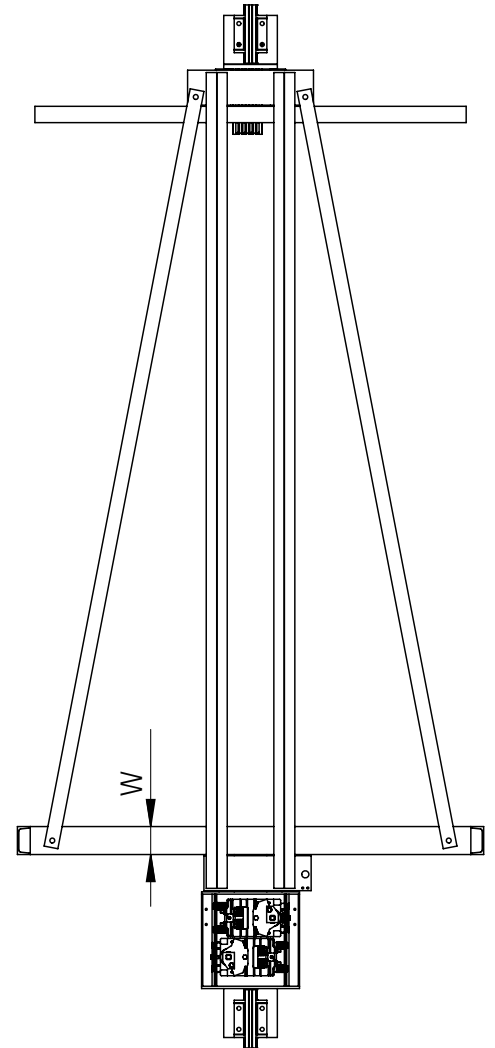
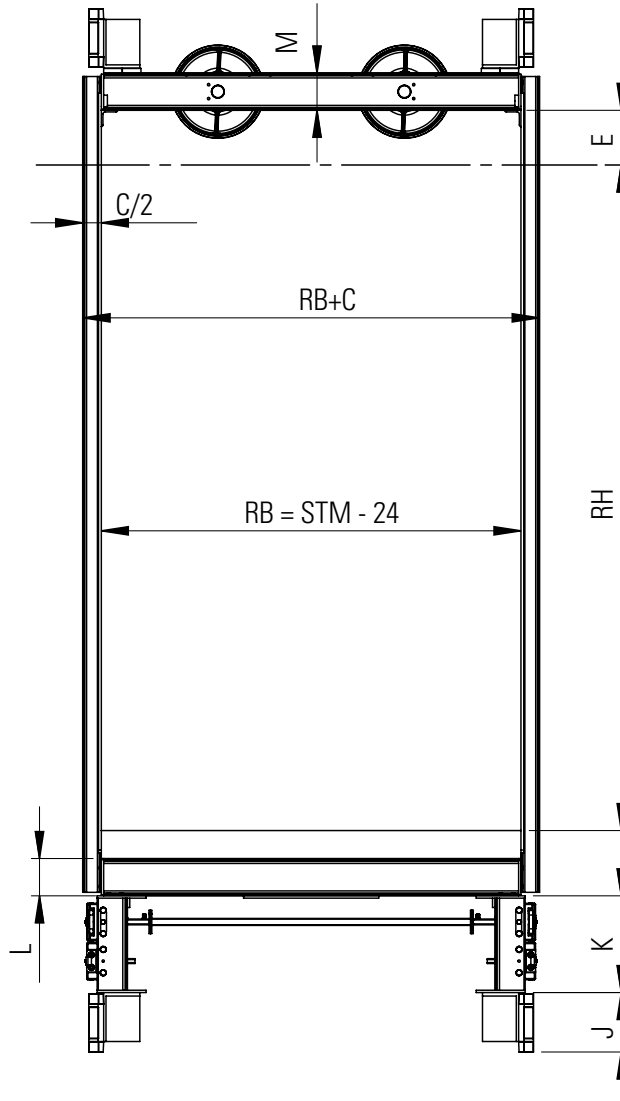

STM	Führungsschienen- Stichmass
RH	Gesamthöhe Fahrkorb
RB	Fahrkorb aussen
RB+C	Rahmen aussen
RT	Rahmentiefe

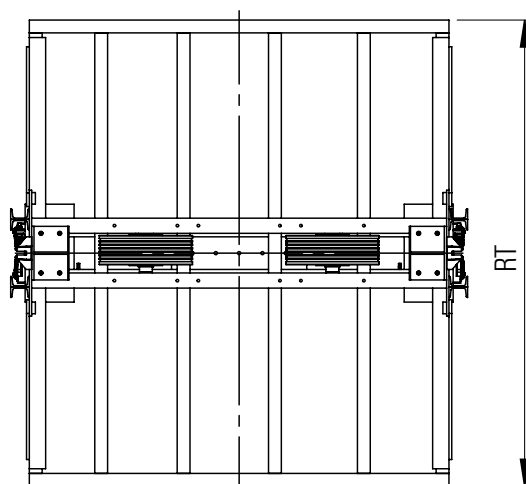

K	Einbauhöhe Fangvorrichtung
230	BF Standard
415	BF Tandem
560	BF Triple

J	Höhe Führungsrolle/-schuh
193	RFP 125
275	RFL 200
140	FS 140
150	FS 150
190	FS 190
250	FS 250