

SHAFT CONSTRUCTION

Pit depth GT 1100 Standard

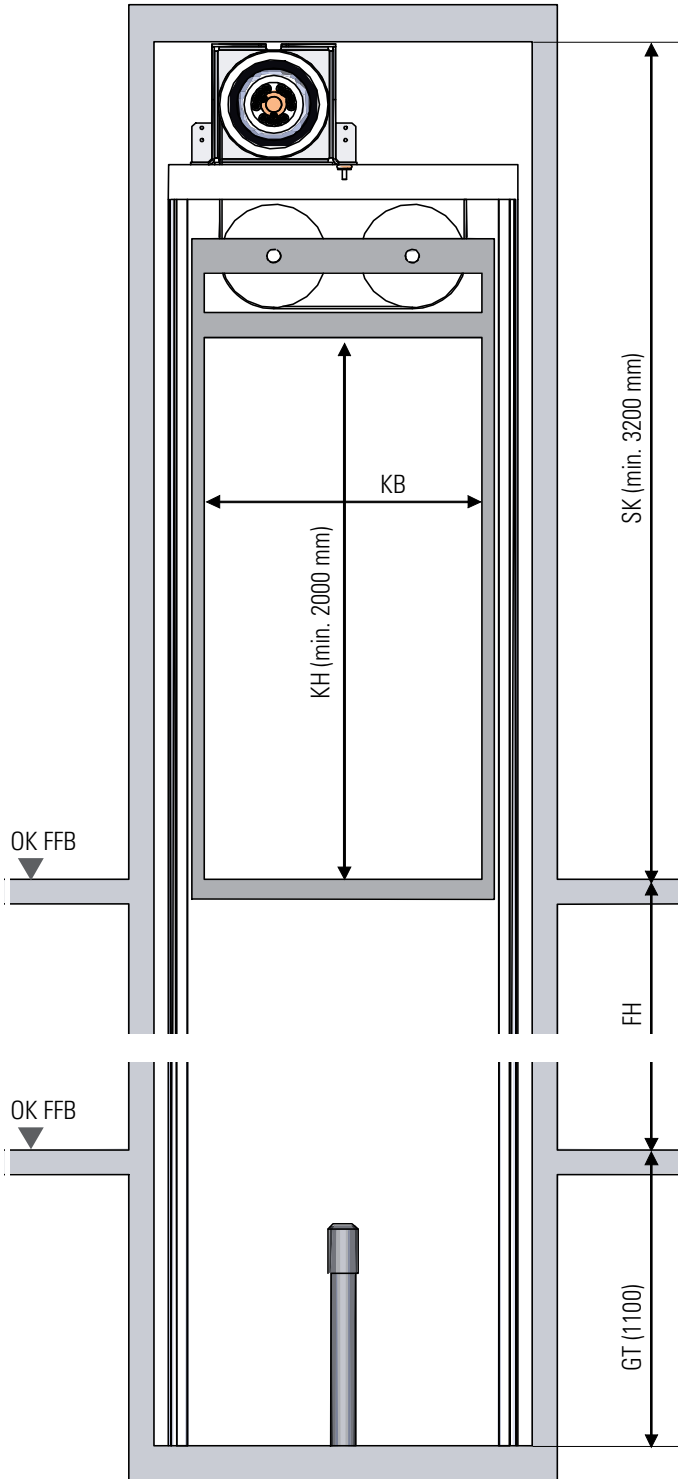

	Dimensions
Travel height FH	up to 22 m
Shaft headroom SK	KH + 1,200 mm (min. 3,200 mm)
Car height inside KH	min. 2,000 mm
Pit depth GT	160 - 1,100 mm

Fold-away bracket mounting on guide rail

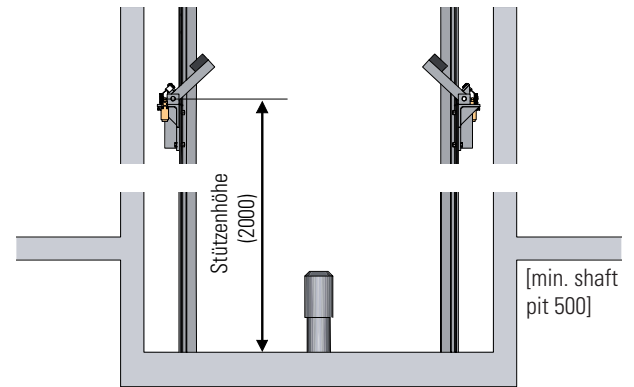

Reduced pit depth GT 500 with telescopic column

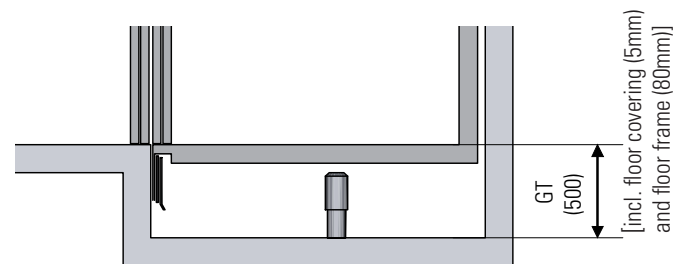

Reduced pit depth GT 160 with fold-away apron

