

DIMENSIONS

CF sm 1 PULLEY ON TOP
SUSPENSION 2:1

TYPE	RH	RB	RT	C/2	D	E	G	H
CF sm630	2,150 - 2,750	max. 1,200	800	50	225	330 (pulley <= 400mm)	350	300
CF sm1000	2,150 - 2,750	max. 1,500						
CF sm1600	2,150 - 2,750	max. 1,600						



CF sm 1 pulley on top with SG, sliding guide shoes

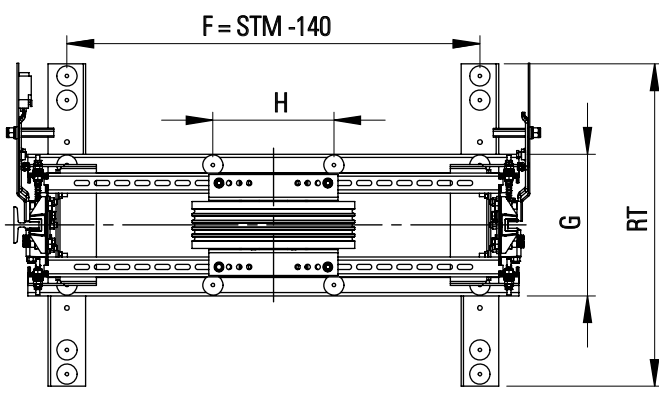
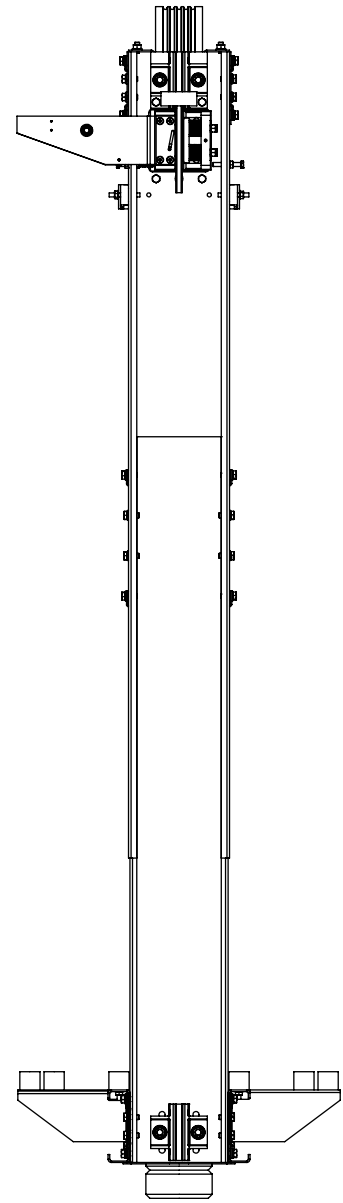
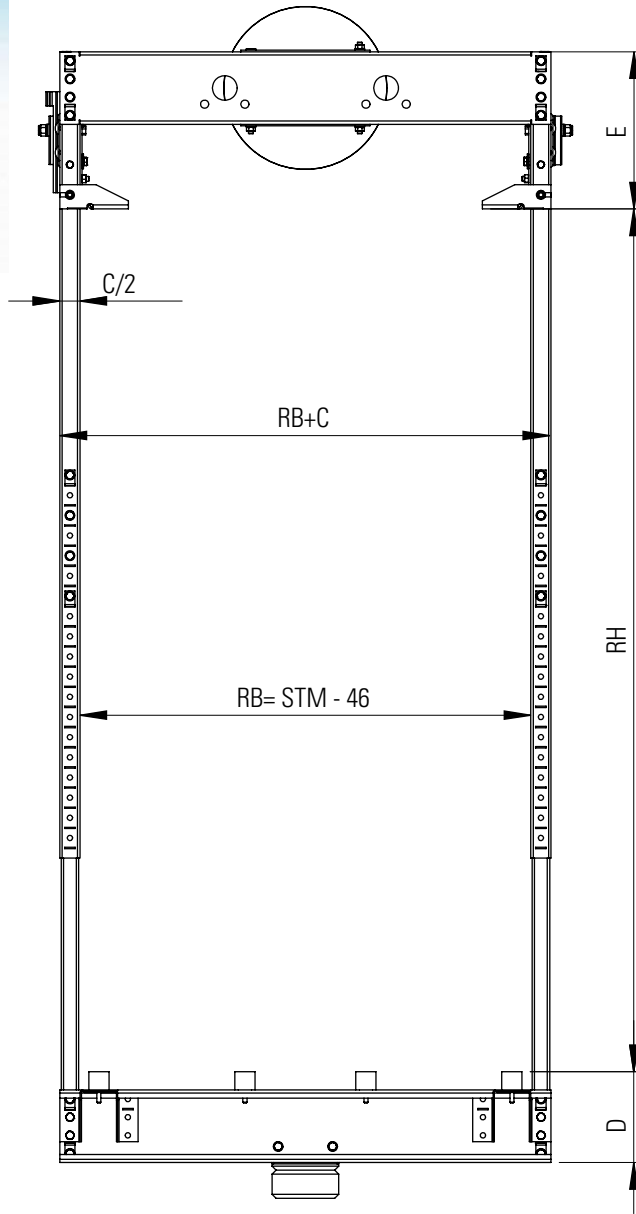

STM	DBG - Distance between guides
RH	Overall height of car
RB	Overall width of car
RB+C	Frame outside
RT	Depth of frame